

Glidlager

2005

STOCKHOLM
Box 510
183 25 TÄBY
Tel: 08-630 28 00
Fax: 08-630 28 90

GÖTEBORG
Backa Bergögata 14
422 46 HISINGS BACKA
Tel: 031-58 50 80
Fax: 031-58 50 81

MALMÖ
Box 9030
200 39 MALMÖ
Tel: 040-21 04 70
Fax: 040-94 59 70

SVENSSON & SVENSSON
Värmlandsvägen 2
691 32 KARLSKOGA
Tel: 0586-371 50
Fax: 0586-379 80

NOMO TRANSMISSIONER
Kong Svends Vej 65
DK-2765 SMØRUM
Tel: +45-44 208 600
Fax: +45-44 208 601



Glidlager

FB 090/092	9-10
FBB 090/092.....	11
NB1-	4-5
NB1F-	6
NB--SF1-	7
NB1-	7
NB--SF2Y	8
NB2Y-	8
Nyliner.....	12-13
Teknisk information	14-21

NB1-

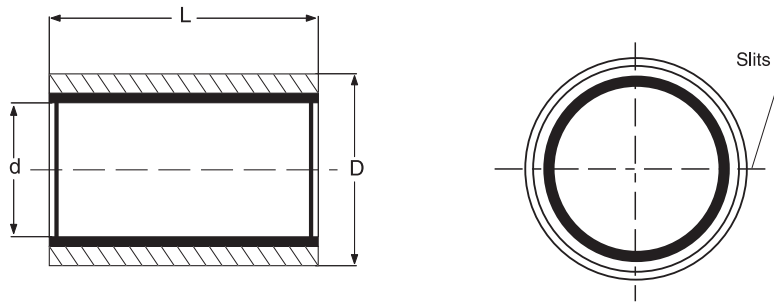

Beteckning	Dimensioner mm		
	d	D	L
NB1-0303	3	4,5	3
NB1-0304	3	4,5	4
NB1-0305	3	4,5	5
NB1-0306	3	4,5	6
NB1-0404	4	5,5	4
NB1-0406	4	5,5	6
NB1-0408	4	5,5	7
NB1-0504	5	7	4
NB1-0505	5	7	5
NB1-0506	5	7	6
NB1-0508	5	7	8
NB1-0605	6	8	5
NB1-0606	6	8	6
NB1-0607	6	8	7
NB1-0608	6	8	8
NB1-0610	6	8	10
NB1-0805	8	10	5
NB1-0806	8	10	6
NB1-0807	8	10	7
NB1-0808	8	10	8
NB1-0810	8	10	10
NB1-0812	8	10	12
NB1-1006	10	12	6
NB1-1007	10	12	7
NB1-1008	10	12	8
NB1-1010	10	12	10
NB1-1012	10	12	12
NB1-1015	10	12	15
NB1-1020	10	12	20
NB1-1206	12	14	6
NB1-1207	12	14	7
NB1-1208	12	14	8
NB1-1210	12	14	10
NB1-1212	12	14	12
NB1-1215	12	14	15
NB1-1220	12	14	20

Beteckning	Dimensioner mm		
	d	D	L
NB1-1308	13	15	8
NB1-1310	13	15	10
NB1-1315	13	15	15
NB1-1410	14	16	10
NB1-1412	14	16	12
NB1-1415	14	16	15
NB1-1420	14	16	20
NB1-1508	15	17	8
NB1-1510	15	17	10
NB1-1512	15	17	12
NB1-1515	15	17	15
NB1-1520	15	17	20
NB1-1525	15	17	25
NB1-1610	16	18	10
NB1-1612	16	18	12
NB1-1615	16	18	15
NB1-1620	16	18	20
NB1-1625	16	18	25
NB1-1810	18	20	10
NB1-1812	18	20	12
NB1-1815	18	20	15
NB1-1820	18	20	20
NB1-1825	18	20	25
NB1-2010	20	23	10
NB1-2012	20	23	12
NB1-2015	20	23	15
NB1-2020	20	23	20
NB1-2025	20	23	25
NB1-2030	20	23	30
NB1-2210	22	25	10
NB1-2212	22	25	12
NB1-2215	22	25	15
NB1-2220	22	25	20
NB1-2225	22	25	25
NB1-2230	22	25	30

Beteckning	Dimensioner mm		
	d	D	L
NB1-2415	24	27	15
NB1-2420	24	27	20
NB1-2425	24	27	25
NB1-2430	24	27	30
NB1-2510	25	28	10
NB1-2512	25	28	12
NB1-2515	25	28	15
NB1-2520	25	28	20
NB1-2525	25	28	25
NB1-2530	25	28	30
NB1-2535	25	28	35
NB1-2540	25	28	40
NB1-2812	28	32	12
NB1-2815	28	32	15
NB1-2820	28	32	20
NB1-2830	28	32	30
NB1-3012	30	34	12
NB1-3015	30	34	15
NB1-3020	30	34	20
NB1-3025	30	34	25
NB1-3030	30	34	30
NB1-3035	30	34	35
NB1-3040	30	34	40
NB1-3220	32	36	20
NB1-3230	32	36	30
NB1-3240	32	36	40
NB1-3512	35	39	12
NB1-3520	35	39	20
NB1-3525	35	39	25
NB1-3530	35	39	30
NB1-3535	35	39	35
NB1-3540	35	39	40
NB1-3550	35	39	50
NB1-3820	38	42	20
NB1-3825	38	42	25
NB1-3830	38	42	30

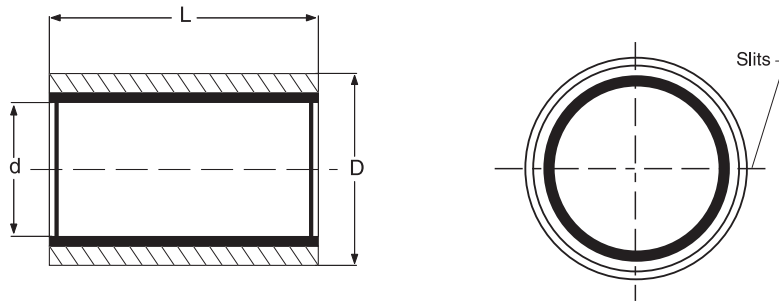

Beteckning	Dimensioner mm		
	d	D	L
NB1-4012	40	44	12
NB1-4020	40	44	20
NB1-4025	40	44	25
NB1-4030	40	44	30
NB1-4040	40	44	40
NB1-4050	40	44	50
NB1-4520	45	50	20
NB1-4525	45	50	25
NB1-4530	45	50	30
NB1-4535	45	50	35
NB1-4540	45	50	40
NB1-4550	45	50	50
NB1-5020	50	55	20
NB1-5025	50	55	25
NB1-5030	50	55	30
NB1-5035	50	55	35
NB1-5040	50	55	40
NB1-5050	50	55	50
NB1-5060	50	55	60
NB1-5530	55	60	30
NB1-5535	55	60	35
NB1-5540	55	60	40
NB1-5550	55	60	50
NB1-5560	55	60	60
NB1-6030	60	65	30
NB1-6035	60	65	35
NB1-6040	60	65	40
NB1-6060	60	65	60
NB1-6070	60	65	70
NB1-6530	65	70	30
NB1-6540	65	70	40
NB1-6550	65	70	50
NB1-6560	65	70	60
NB1-6570	65	70	70
NB1-7035	70	75	35
NB1-7040	70	75	40

Beteckning	Dimensioner mm		
	d	D	L
NB1-7050	70	75	50
NB1-7060	70	75	60
NB1-7080	70	75	80
NB1-7530	75	80	30
NB1-7535	75	80	35
NB1-7540	75	80	40
NB1-7550	75	80	50
NB1-7560	75	80	60
NB1-7580	75	80	80
NB1-8040	80	85	40
NB1-8050	80	85	50
NB1-8060	80	85	60
NB1-8080	80	85	80
NB1-8540	85	90	40
NB1-8560	85	90	60
NB1-8580	85	90	80
NB1-9020	90	95	20
NB1-9035	90	95	35
NB1-9040	90	95	40
NB1-9060	90	95	60
NB1-9090	90	95	90
NB1-10050	100	105	50
NB1-10060	100	105	60
NB1-10080	100	105	80
NB1-10560	105	110	60
NB1-10580	105	110	80
NB1-11060	110	115	60
NB1-11080	110	115	80
NB1-12060	120	125	60
NB1-12080	120	125	80
NB1-120100	120	125	100
NB1-13060	130	135	60
NB1-13080	130	135	80

Beteckning	Dimensioner mm		
	d	D	L
NB1-14060	140	145	60
NB1-14080	140	145	80
NB1-140100	140	145	100
NB1-15050	150	155	50
NB1-15080	150	155	80
NB1-150100	150	155	100
NB1-16060	160	165	60
NB1-16080	160	165	80
NB1-160100	160	165	100

NB1F-

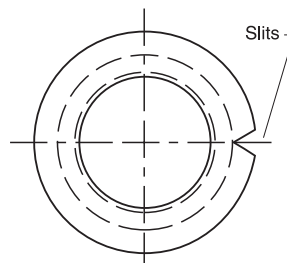
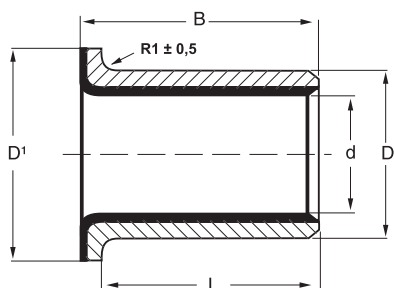

Beteckning	Dimensioner mm			
	d	D	D'	B
NB1F-0405	4	5,5	9	5
NB1F-0505	5	7	10	5
NB1F-0506	5	7	10	6
NB1F-0605	6	8	12	5
NB1F-0606	6	8	12	6
NB1F-0607	6	8	12	7
NB1F-0608	6	8	12	8
NB1F-0807	8	10	15	7
NB1F-0809	8	10	15	9
NB1F-1007	10	12	18	7
NB1F-1008	10	12	18	8
NB1F-1009	10	12	18	9
NB1F-1011	10	12	18	11
NB1F-1012	10	12	18	12
NB1F-1016	10	12	18	16
NB1F-1207	12	14	20	7
NB1F-1209	12	14	20	9
NB1F-1211	12	14	20	11
NB1F-1213	12	14	20	13
NB1F-1217	12	14	20	17
NB1F-1410	14	16	22	10
NB1F-1412	14	16	22	12
NB1F-1417	14	16	22	17
NB1F-1509	15	17	23	9
NB1F-1513	15	17	23	13
NB1F-1516	15	17	23	16
NB1F-1612	16	18	24	12
NB1F-1616	16	18	24	16
NB1F-1626	16	18	24	26
NB1F-1812	18	20	26	12
NB1F-1813	18	20	26	13
NB1F-1817	18	20	26	17
NB1F-1822	18	20	26	22

Beteckning	Dimensioner mm			
	d	D	D'	B
NB1F-20115	20	23	30	11,5
NB1F-20135	20	23	30	13,5
NB1F-20165	20	23	30	16,5
NB1F-20215	20	23	30	21,5
NB1F-20265	20	23	30	26,5
NB1F-2215	22	25	32	15
NB1F-2215	22	25	32	21,5
NB1F-2515	25	28	35	11,5
NB1F-2565	25	28	35	16,5
NB1F-2515	25	28	35	21,5
NB1F-2565	25	28	35	26,5
NB1F-2615	26	30	38	15
NB1F-3016	30	34	42	16
NB1F-3026	30	34	42	26
NB1F-3516	35	39	49	16
NB1F-3526	35	39	49	26
NB1F-3527	35	39	49	27
NB1F-4016	40	44	54	16
NB1F-4026	40	44	54	26
NB1F-4040	40	44	54	40
NB1F-4520	45	50	60	20
NB1F-4525	45	50	60	25
NB1F-4530	45	50	60	30
NB1F-4540	45	50	60	40
NB1F-5020	50	55	65	20
NB1F-5030	50	55	65	30
NB1F-5040	50	55	65	40
NB1F-5530	55	60	70	30
NB1F-5540	55	60	70	40
NB1F-6030	60	65	75	30
NB1F-6040	60	65	75	40

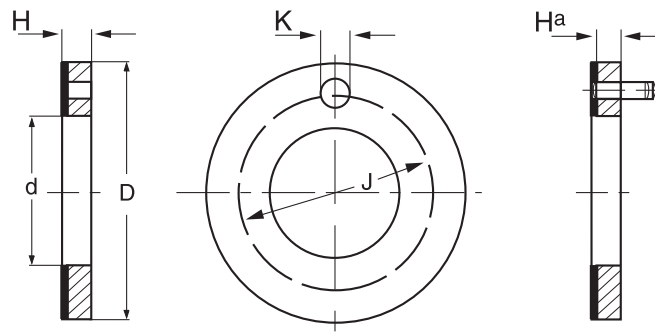

NB1-

Beteckning	Dimensioner mm					Ursvarningsdjup H ^a ±0,2	Matchande bussning id
	d	D	H	J	K ^{+0,4 +0,1}		
NB-08-SF1	8	16	1,5	12	1,3	1	6
NB-10-SF1	10	20	1,5	15	1,5	1	8
NB-12-SF1	12	24	1,5	18	1,5	1	10
NB-14-SF1	14	26	1,5	20	2	1	12
NB-16-SF1	16	30	1,5	23	2	1	14
NB-18-SF1	18	32	1,5	25	2	1	16
NB-20-SF1	20	36	1,5	28	3	1	18
NB-22-SF1	22	38	1,5	30	3	1	20
NB-24-SF1	24	42	1,5	33	3	1	22
NB-26-SF1	26	44	1,5	35	3	1	24
NB-28-SF1	28	48	1,5	38	4	1	25
NB-32-SF1	32	54	1,5	43	4	1	30
NB-38-SF1	38	62	1,5	50	4	1	35
NB-42-SF1	42	66	1,5	54	4	1	40
NB-48-SF1	48	74	2	61	4	1,5	45
NB-52-SF1	52	78	2	65	4	1,5	50
NB-62-SF1	62	90	2	76	4	1,5	60

Toleranser: $d = \begin{matrix} +0,25 \\ 0 \end{matrix}$ $D = \begin{matrix} +0 \\ -0,25 \end{matrix}$ $H = \begin{matrix} +0 \\ -0,05 \end{matrix}$ $J = \pm 0,12$

Beteckning	Dimensioner mm		
	H	B	L
NB1-100	1,00	200	500
NB1-150	1,50	200	500
NB1-200	2,00	200	500
NB1-250	2,50	200	500

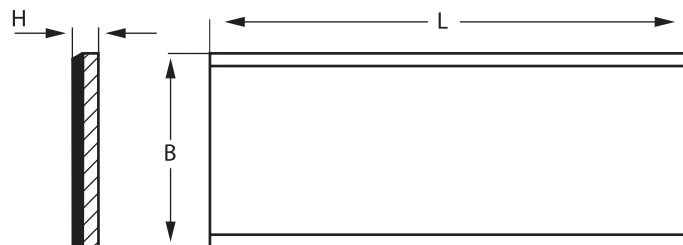

Toleranser: $B = \pm 1$ $L = \pm 1$ $H = \begin{matrix} 0 \\ -0,04 \end{matrix}$

NB2Y..., NB...SF2Y

Med smörjfickor

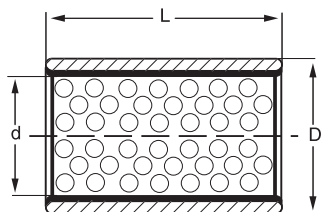

NB2Y

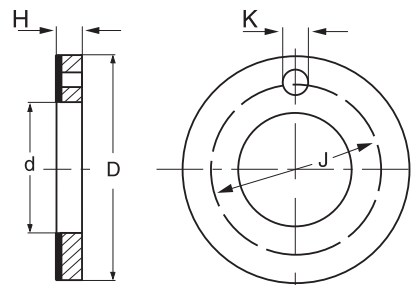
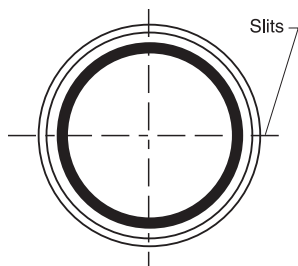

NB-SF2Y

Beteckning	Dimensioner mm		
	d	D	L
NB2Y-0808	8	10	8
NB2Y-0810	8	10	10
NB2Y-1010	10	12	10
NB2Y-1015	10	12	15
NB2Y-1020	10	12	20
NB2Y-1210	12	14	10
NB2Y-1212	12	14	12
NB2Y-1215	12	14	15
NB2Y-1220	12	14	20
NB2Y-1225	12	14	25
NB2Y-1415	14	16	15
NB2Y-1420	14	16	20
NB2Y-1515	15	17	15
NB2Y-1520	15	17	20
NB2Y-1525	15	17	25
NB2Y-1615	16	18	15
NB2Y-1620	16	18	20
NB2Y-1625	16	18	25
NB2Y-1815	18	20	15
NB2Y-1820	18	20	20
NB2Y-1825	18	20	25
NB2Y-2015	20	23	15
NB2Y-2020	20	23	20
NB2Y-2025	20	23	25
NB2Y-2030	20	23	30
NB2Y-2215	22	25	15
NB2Y-2220	22	25	20
NB2Y-2225	22	25	25
NB2Y-2420	24	27	20
NB2Y-2520	25	28	20
NB2Y-2525	25	28	25
NB2Y-2530	25	28	30
NB2Y-2820	28	32	20
NB2Y-2830	28	32	30
NB2Y-3020	30	34	20
NB2Y-3030	30	34	30
NB2Y-3040	30	34	40

Beteckning	Dimensioner mm		
	d	D	L
NB2Y-3230	32	36	30
NB2Y-3520	35	39	20
NB2Y-3530	35	39	30
NB2Y-3535	35	39	35
NB2Y-3540	35	39	40
NB2Y-3550	35	39	50
NB2Y-4020	40	44	20
NB2Y-4030	40	44	30
NB2Y-4040	40	44	40
NB2Y-4050	40	44	50
NB2Y-4520	45	50	20
NB2Y-4530	45	50	30
NB2Y-4540	45	50	40
NB2Y-4550	45	50	50
NB2Y-5030	50	55	30
NB2Y-5040	50	55	40
NB2Y-5050	50	55	50
NB2Y-5060	50	55	60
NB2Y-5530	55	60	30
NB2Y-5540	55	60	40
NB2Y-5550	55	60	50
NB2Y-6030	60	65	30
NB2Y-6040	60	65	40
NB2Y-6050	60	65	50
NB2Y-6060	60	65	60
NB2Y-6070	60	65	70
NB2Y-6540	65	70	40
NB2Y-7040	70	75	40
NB2Y-7070	70	75	70
NB2Y-7540	75	80	40
NB2Y-8080	80	85	80
NB2Y-9040	90	95	40
NB2Y-9060	90	95	60
NB2Y-10030	100	105	30

Beteckning	Dimensioner mm		
	d	D	H
NB-10-SF2Y	10	20	1,5
NB-12-SF2Y	12	24	1,5
NB-14-SF2Y	14	26	1,5
NB-16-SF2Y	16	30	1,5
NB-18-SF2Y	18	32	1,5
NB-20-SF2Y	20	36	1,5
NB-22-SF2Y	22	38	1,5
NB-24-SF2Y	24	42	1,5
NB-26-SF2Y	26	44	1,5
NB-28-SF2Y	28	48	1,5
NB-32-SF2Y	32	54	1,5
NB-38-SF2Y	38	62	1,5
NB-42-SF2Y	42	66	1,5
NB-48-SF2Y	48	74	2
NB-52-SF2Y	52	78	2
NB-62-SF2Y	62	90	2

FB 090/092

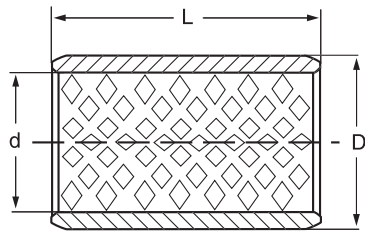

FB090

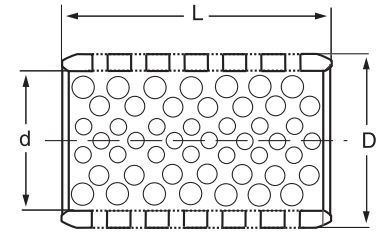
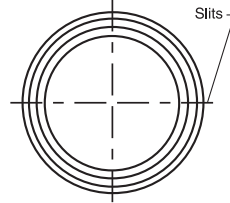

FB092

Beteckning	Dimensioner mm		
	d	D	L
FB 090/092-1010	10	12	10
FB 090/092-1015	10	12	15
FB 090/092-1210	12	14	10
FB 090/092-1215	12	14	15
FB 090/092-1220	12	14	20
FB 090/092-1410	14	16	10
FB 090/092-1415	14	16	15
FB 090/092-1420	14	16	20
FB 090/092-1425	14	16	25
FB 090/092-1510	15	17	10
FB 090/092-1515	15	17	15
FB 090/092-1520	15	17	20
FB 090/092-1525	15	17	25
FB 090/092-1610	16	18	10
FB 090/092-1615	16	18	15
FB 090/092-1620	16	18	20
FB 090/092-1625	16	18	25
FB 090/092-1810	18	20	10
FB 090/092-1815	18	20	15
FB 090/092-1820	18	20	20
FB 090/092-1825	18	20	25
FB 090/092-2010	20	23	10
FB 090/092-2015	20	23	15
FB 090/092-2020	20	23	20
FB 090/092-2025	20	23	25
FB 090/092-2030	20	23	30
FB 090/092-2215	22	25	15
FB 090/092-2220	22	25	20
FB 090/092-2225	22	25	25
FB 090/092-2230	22	25	30
FB 090/092-2240	22	25	40
FB 090/092-2430	24	27	30
FB 090/092-2515	25	28	15
FB 090/092-2520	25	28	20
FB 090/092-2525	25	28	25
FB 090/092-2530	25	28	30
FB 090/092-2815	25	31	15
FB 090/092-2820	28	31	20
FB 090/092-2825	28	31	25
FB 090/092-2830	28	31	30
FB 090/092-3015	30	34	15
FB 090/092-3020	30	34	20
FB 090/092-3025	30	34	25

Beteckning	Dimensioner mm		
	d	D	L
FB 090/092-3030	30	34	30
FB 090/092-3040	30	34	40
FB 090/092-3215	32	36	15
FB 090/092-3220	32	36	20
FB 090/092-3225	32	36	25
FB 090/092-3230	32	36	30
FB 090/092-3240	32	36	40
FB 090/092-3515	35	39	15
FB 090/092-3520	35	39	20
FB 090/092-3525	35	39	25
FB 090/092-3530	35	39	30
FB 090/092-3535	35	39	35
FB 090/092-3540	35	39	40
FB 090/092-3550	35	39	50
FB 090/092-4020	40	44	20
FB 090/092-4025	40	44	25
FB 090/092-4030	40	44	30
FB 090/092-4040	40	44	40
FB 090/092-4050	40	44	50
FB 090/092-4060	40	44	60
FB 090/092-4520	45	50	20
FB 090/092-4525	45	50	25
FB 090/092-4530	45	50	30
FB 090/092-4540	45	50	40
FB 090/092-4550	45	50	50
FB 090/092-4560	45	50	60
FB 090/092-5025	50	55	25
FB 090/092-5030	50	55	30
FB 090/092-5040	50	55	40
FB 090/092-5050	50	55	50
FB 090/092-5060	50	55	60
FB 090/092-5520	55	60	20
FB 090/092-5525	55	60	25
FB 090/092-5530	55	60	30
FB 090/092-5540	55	60	40
FB 090/092-5550	55	60	50
FB 090/092-5560	55	60	60
FB 090/092-6025	60	65	25
FB 090/092-6030	60	65	30
FB 090/092-6035	60	65	35
FB 090/092-6040	60	65	40
FB 090/092-6050	60	65	50
FB 090/092-6060	60	65	60
FB 090/092-6080	60	65	80
FB 090/092-6090	60	65	90

FB 090/092

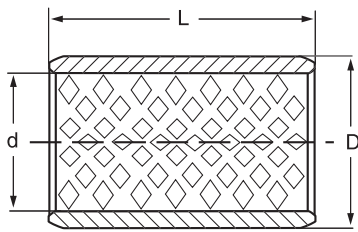

FB090

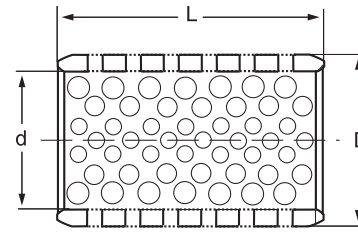
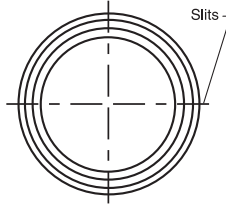

FB092

Beteckning	Dimensioner mm		
	d	D	L
FB 090/092-6530	65	70	30
FB 090/092-6540	65	70	40
FB 090/092-6550	65	70	50
FB 090/092-6560	65	70	60
FB 090/092-6580	65	70	80
FB 090/092-7040	70	75	40
FB 090/092-7050	70	75	50
FB 090/092-7060	70	75	60
FB 090/092-7070	70	75	70
FB 090/092-7080	70	75	80
FB 090/092-7090	70	75	90
FB 090/092-7530	75	80	30
FB 090/092-7540	75	80	40
FB 090/092-7560	75	80	60
FB 090/092-7580	75	80	80
FB 090/092-8030	80	85	30
FB 090/092-8040	80	85	40
FB 090/092-8060	80	85	60
FB 090/092-8080	80	85	80
FB 090/092-8530	85	90	30
FB 090/092-8540	85	90	40
FB 090/092-8560	85	90	60
FB 090/092-8580	85	90	80
FB 090/092-9040	90	95	40
FB 090/092-9060	90	95	60
FB 090/092-9080	90	95	80
FB 090/092-9090	90	95	90
FB 090/092-10050	100	105	50
FB 090/092-10060	100	105	60
FB 090/092-10095	100	105	95
FB 090/092-10560	105	110	60
FB 090/092-105100	105	110	100
FB 090/092-11060	110	115	60
FB 090/092-110100	110	115	100
FB 090/092-11560	115	120	60
FB 090/092-115100	115	120	100
FB 090/092-12060	120	125	60
FB 090/092-120100	120	125	100
FB 090/092-12560	125	130	60
FB 090/092-125100	125	130	100
FB 090/092-13060	130	135	60
FB 090/092-130100	130	135	100
FB 090/092-13560	135	140	60
FB 090/092-135100	135	140	100

Beteckning	Dimensioner mm		
	d	D	L
FB 090/092-14060	140	145	60
FB 090/092-140100	140	145	100
FB 090/092-14560	145	150	60
FB 090/092-145100	145	150	100
FB 090/092-15060	150	155	60
FB 090/092-150100	150	155	100
FB 090/092-15560	155	160	60
FB 090/092-155100	155	160	100
FB 090/092-16060	160	165	60
FB 090/092-160100	160	165	100
FB 090/092-16560	165	170	60
FB 090/092-165100	165	170	100
FB 090/092-17060	170	175	60
FB 090/092-170100	170	175	100
FB 090/092-17560	175	180	60
FB 090/092-175100	175	180	100
FB 090/092-18060	180	185	60
FB 090/092-180100	180	185	100
FB 090/092-18560	185	190	60
FB 090/092-185100	185	190	100
FB 090/092-19060	190	195	60
FB 090/092-190100	190	195	100
FB 090/092-19560	195	200	60
FB 090/092-195100	195	200	100
FB 090/092-20060	200	205	60
FB 090/092-200100	200	205	100
FB 090/092-21560	215	220	60
FB 090/092-215100	215	220	100
FB 090/092-22560	225	230	60
FB 090/092-225100	225	230	100
FB 090/092-23560	235	240	60
FB 090/092-235100	235	240	100
FB 090/092-24560	245	250	60
FB 090/092-245100	245	250	100
FB 090/092-27560	275	280	60
FB 090/092-275100	275	280	100
FB 090/092-28560	285	290	60
FB 090/092-285100	285	290	100
FB 090/092-30060	300	305	60
FB 090/092-300100	300	305	100

FBB 090/092

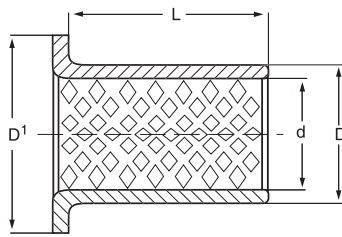

FBB090

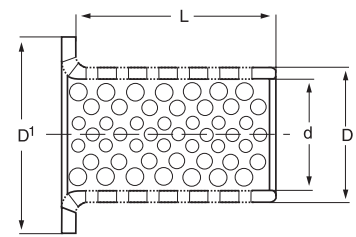
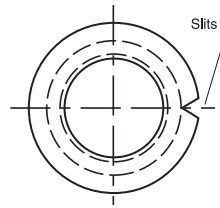

FBB092

Beteckning	Dimensioner mm			
	d	D	D'	B
FBB 090/092-2515	25	28	35	15
FBB 090/092-2525	25	28	35	25
FBB 090/092-3020	30	34	45	20
FBB 090/092-3520	30	34	45	30
FBB 090/092-3535	35	39	50	20
FBB 090/092-4025	40	44	55	25
FBB 090/092-4040	40	44	55	40
FBB 090/092-4530	45	50	60	30
FBB 090/092-4545	45	50	60	45
FBB 090/092-4550	45	50	60	50
FBB 090/092-5030	50	55	65	30
FBB 090/092-5050	50	55	65	50
FBB 090/092-5530	50	55	65	50
FBB 090/092-5550	55	60	70	50
FBB 090/092-6030	60	65	75	30
FBB 090/092-6035	60	65	75	35
FBB 090/092-6060	60	65	75	60
FBB 090/092-6530	65	70	80	30
FBB 090/092-6560	65	70	80	60
FBB 090/092-7040	70	75	85	40
FBB 090/092-7070	70	75	85	70
FBB 090/092-7540	75	80	90	40
FBB 090/092-7570	75	80	90	70
FBB 090/092-8040	80	85	100	40
FBB 090/092-8080	80	85	100	80
FBB 090/092-9050	90	95	110	50
FBB 090/092-9090	90	95	110	90
FBB 090/092-10050	100	105	120	50
FBB 090/092-10090	100	105	120	90

Beteckning	Dimensioner mm			
	d	D	D'	B
FBB 090/092-11050	110	115	130	50
FBB 090/092-11090	110	115	130	90
FBB 090/092-12050	120	125	140	50
FBB 090/092-12090	120	125	140	90
FBB 090/092-13060	130	135	155	60
FBB 090/092-13090	130	135	155	90
FBB 090/092-14060	140	145	165	60
FBB 090/092-14090	140	145	165	90
FBB 090/092-15060	150	155	180	60
FBB 090/092-15090	150	155	180	90
FBB 090/092-16060	160	165	190	60
FBB 090/092-16090	160	165	190	90
FBB 090/092-17060	170	175	200	60
FBB 090/092-17090	170	175	200	90
FBB 090/092-18060	180	185	215	60
FBB 090/092-18090	180	185	215	90
FBB 090/092-19060	190	195	225	60
FBB 090/092-19090	190	195	225	90
FBB 090/092-20060	200	205	235	60
FBB 090/092-20090	200	205	235	90
FBB 090/092-22560	225	230	260	60
FBB 090/092-22590	225	230	260	90
FBB 090/092-25060	250	255	290	60
FBB 090/092-25090	250	255	290	90
FBB 090/092-26560	265	270	305	60
FBB 090/092-26590	265	270	305	90
FBB 090/092-28560	285	290	325	60
FBB 090/092-28590	285	290	325	90
FBB 090/092-30060	300	305	340	60
FBB 090/092-30090	300	305	340	90

Med fläns

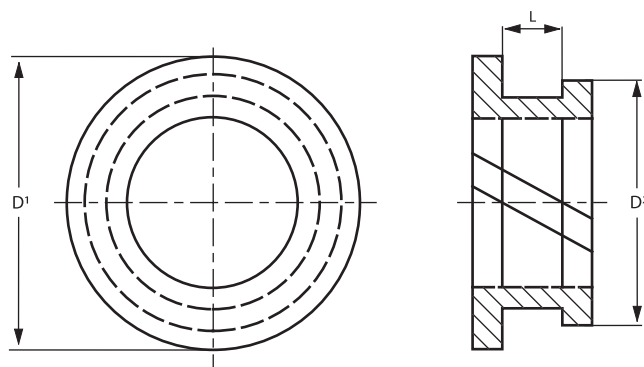

Serie 801...

Beteckning	d* -0,1 - 0	Flänsdiameter				Rek. vägg- tjocklek	Statisk bärighet N	Radiell bärighet			
		D	D¹	D²	L			10 rNB N	50 rNB N	100rNB N	250 rNB N
8010A	3,025	4,2	6	4,8	2	1,45-1,92	71	22	18	13	9
8011A	4,025	5,2	7	5,9	2	1,45-1,92	89	40	27	22	18
8012A	5,025	6,2	8	6,8	2	1,45-1,92	120	49	44	27	18
8013A	6,025	7,2	11	7,8	2	1,45-1,92	151	58	53	32	18
8014A	8,025	9,6	13	10,4	2	1,45-1,92	187	67	58	36	18
8015A	10,025	11,6	15	12,4	2	1,45-1,92	267	71	62	40	22
8016A	12,025	13,6	17	14,4	2	1,45-1,92	356	89	71	49	22
8010A-642	3,025	4,2	6	4,8	2	1,45-1,92	161	50	40	30	20
8011A-642	4,025	5,2	7	5,9	2	1,45-1,92	202	91	61	50	40
8012A-642	5,025	6,2	8	6,8	2	1,45-1,92	273	111	101	61	40
8013A-642	6,025	7,2	11	7,8	2	1,45-1,92	343	131	121	74	40
8014A-642	8,025	9,6	13	10,4	2	1,45-1,92	424	151	131	81	40
8015A-642	10,025	11,6	15	12,4	2	1,45-1,92	606	161	141	91	50
8016A-642	12,025	13,6	17	14,4	2	1,45-1,92	807	202	161	111	50

* Efter montering i hus med min mått enligt D

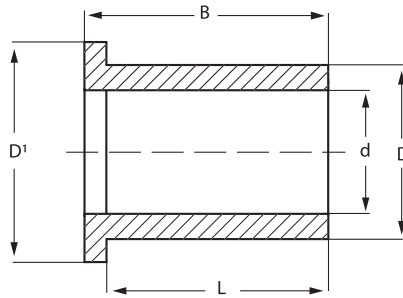

Serie 800...

Beteckning		Nominell inner-diameter	d* +0,05 -0	D	L +0 -0,4	Fläns	
Nyliner	Nyliner Plus					D'	+0 -0,13
8000A	8000A-642	4	4,025	5,2	4	7,0	0,6
8001A	8001A-642	5	5,025	6,2	5	8,0	0,6
8002A	8002A-642	6	6,025	7,2	6	9,5	0,6
8003A	8003A-642	8	8,025	9,6	8	12,0	0,8
8004A	8004A-642	10	10,025	11,6	10	15,0	0,8
8005A	8005A-642	12	12,025	13,6	12	18,0	0,8
8006A	8006A-642	14	14,025	15,6	14	21,0	0,8
8007A	8007A-642	16	16,025	17,6	16	24,0	0,8
8008A	8008A-642	20	20,025	21,6	20	30,0	0,8
8009A	8009A-642	25	25,025	27,4	25	37,5	1,2

* Efter montering i hus med min mått enligt D.

Radiell bärighet*, N

Beteckning	Statisk bärighet	rNB					
		10	25	50	100	250	500
8000A	298	42	38	36	22	9	4
8001A	311	56	51	49	36	22	13
8002A	556	93	80	67	49	22	13
8003A	898	160	142	124	89	40	18
8004A	1 321	253	236	200	147	49	18
8005A	2 312	400	351	298	147	49	18
8006A	2 579	458	365	325	147	58	22
8007A	3 690	658	529	467	213	84	31
8008A	5 335	1023	831	667	302	138	80
8009A	9 515	1632	1334	867	347	138	80

Radiell bärighet*, N

Beteckning	Statisk bärighet	rNB					
		10	25	50	100	250	500
8000A-642	676	96	86	81	50	20	10
8001A-642	707	126	116	111	81	50	30
8002A-642	1262	212	182	151	111	50	30
8003A-642	2039	363	323	283	202	91	40
8004A-642	2998	575	535	454	333	111	40
8005A-642	5248	908	797	676	333	111	40
8006A-642	5854	1040	828	737	333	131	50
8007A-642	8377	1494	1201	1060	484	192	71
8008A-642	12112	2321	1887	1514	686	313	182
8009A-642	21599	3704	3028	1968	787	313	182

För mer teknisk information om Nyliner, kontakta Nomo Kullager AB.

**Rekommenderade dimensioner
NB1-, NB1-F**

Radiallager	
Lagrets innerdiameter	Rekommenderad axetolerans
3 - 8	-0,013 -0,028
10 - 18	-0,016 -0,024
20 - 30	-0,020 -0,041
32 - 45	-0,025 -0,050
50 - 75	-0,030 -0,060
80 - 110	0 -0,035
120 - 160	0 -0,040
180 - 220	0 -0,046
250 - 300	0 -0,052
Lagrets ytterdiameter	Rekommenderad hustolerans
4,5 - 10	H7 +0,015 0
12 - 18	H7 +0,018 0
19 - 28	H7 +0,021 0
32 - 50	H7 +0,025 0
55 - 80	H7 +0,030 0
85 - 125	H7 +0,035 0
130 - 165	H7 +0,040 0
185 - 225	H7 +0,046 0
255 - 305	H7 +0,052 0

Flänslager	
Lagrets innerdiameter	Rekommenderad axetolerans
4 - 8	-0,013 -0,028
10 - 18	-0,016 -0,034
20 - 26	-0,020 -0,041
30 - 40	-0,025 -0,050
50 - 60	-0,030 -0,060
Lagrets ytterdiameter	Rekommenderad hustolerans
4,5 - 10	H7 +0,015 0
12 - 18	H7 +0,018 0
20 - 30	H7 +0,021 0
34 - 50	H7 +0,025 0
55 - 65	H7 +0,030 0

Rekommenderade dimensioner NB2Y-

Radiallager

Lagrets innerdiameter	Rekommenderad axetolerans												
8 - 10	0 -0,022												
12 - 18	0 -0,027												
20 - 30	0 -0,033												
35 - 45	0 -0,039												
50 - 80	0 -0,046												
85 - 110	0 -0,054												
<table border="1" style="width: 100%; border-collapse: collapse;"> <thead> <tr> <th style="text-align: left;">Lagrets ytterdiameter</th> <th style="text-align: left;">Rekommenderad hustolerans</th> </tr> </thead> <tbody> <tr> <td>8 - 18</td> <td>H7 +0,018 0</td> </tr> <tr> <td>20 - 28</td> <td>H7 +0,021 0</td> </tr> <tr> <td>32 - 50</td> <td>H7 +0,025 0</td> </tr> <tr> <td>55 - 80</td> <td>H7 +0,030 0</td> </tr> <tr> <td>85 - 105</td> <td>H7 +0,035 0</td> </tr> </tbody> </table>		Lagrets ytterdiameter	Rekommenderad hustolerans	8 - 18	H7 +0,018 0	20 - 28	H7 +0,021 0	32 - 50	H7 +0,025 0	55 - 80	H7 +0,030 0	85 - 105	H7 +0,035 0
Lagrets ytterdiameter	Rekommenderad hustolerans												
8 - 18	H7 +0,018 0												
20 - 28	H7 +0,021 0												
32 - 50	H7 +0,025 0												
55 - 80	H7 +0,030 0												
85 - 105	H7 +0,035 0												

NB1-, NB1F-, NB2Y- Konstruktion och egenskaper

NOMO glidlager är uppbyggda på en stålstomme som ger en mekanisk styrka och minimerar temperaturkänsligheten. På detta finns ett poröst lager tennbrons som är fullständigt bly- och PTFE-, eller acetalplast-impregnerat. Några av de mest utmärkande egenskaperna är:

- behöver ej smörjas (gäller endast NB1)
- tål hög belastning samt stötbastning
- låg friktionskoefficient
- mycket lågt slitage
- inga ”stick-slip” problem
- stort temperaturområde

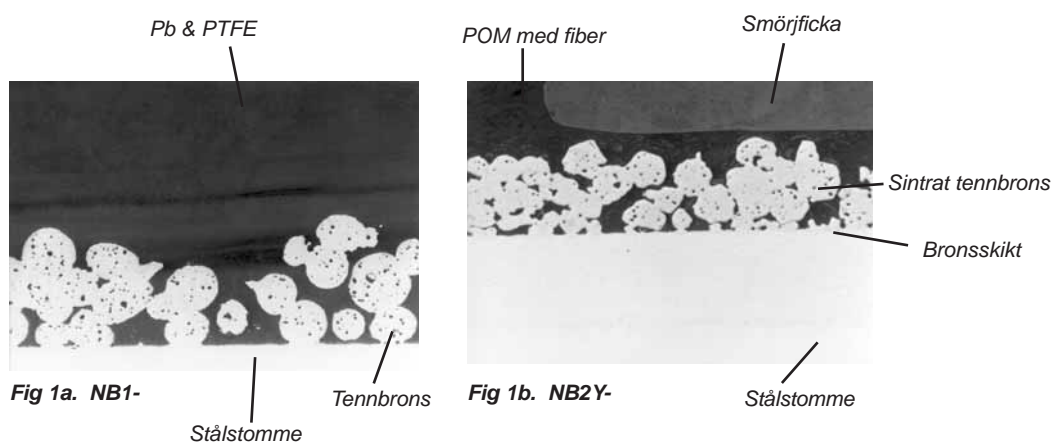

Tabell 1. Fysikaliska egenskaper, NB1-

Temperaturområde	-195°C - +280°C
Bärighet	140 N/mm ²
Värmeutvidgningskoefficient	Parallellt till lagerytan 11x10 ⁻⁶ /°C Vinkelrät mot lagerytan 30x10 ⁻⁶ /°C
Värmeledningsförmåga	0,1 cal/sek x cm x °C
Friktionskoefficient	0,04 - 0,20
Max glidhastighet	5 m/s

Tabell 1a. Fysikaliska egenskaper, NB2Y-

Temperaturområde	-40°C - +130°C
Bärighet	70 N/mm ²
Glidskikt - tjocklek	0,3 - 0,4 mm
Max glidhastighet	2,5 m/s
Friktionskoefficient	0,05 - 0,25

Brukbarhetstid

Lagerslitaget efter inkörningsperioden bestäms mer eller mindre av belastningen samt glidhastigheten. Slitaget ökar nästan i proportion med produkten av den specifika lagerbelastningen P (kg/cm²) på lagret och glidhastigheten V (m/min).

Tabell 2
Förhållande PV-värde – brukbarhetstid

Applikationer	Lagret roterar	Pendelrörelser /roterande axel	Glidbricka
Livslängd (H)	$\frac{1200.000 \times f}{PV}$	$\frac{600.000 \times f}{PV}$	$\frac{450.000 \times f}{PV}$

Tabell 3
Driftsförhållande koefficient f

smörjningsförhållande	Lagerhusmaterial	Omgivningstemperatur					
		25	50	100	150	200	280
Ej smort	Aluminium	1,2	1,1	0,7	0,5	0,2	0,1
	Järn	1	0,9	0,6	0,4	0,2	0,1
Smort	-	2	1,5	1,0	0,6	-	-

Beräkning av PV-värde (PV:kg/cm² x m/min), all typer utom Nyliner

Roterande belastning

Där: P = den specifika belastningen, kg/cm²
 V = glidhastigheten, m/min.
 W = belastningen, kg
 L = lagrets bredd, mm
 d = håldiametern, mm
 D = ytterdiametern, mm
 N = rpm

Tabell 4
Roterande belastning

	P	V	PV
Bussning	$\frac{W}{L \times d} \times 100$	$\frac{\pi \times d \times N}{1000}$	$\frac{\pi \times W \times N}{10 \times L}$
Glidbricka	$\frac{W}{\pi(D^2-d^2)} \times 400$	$\frac{\pi(D+d)N}{2000}$	$\frac{W \times N}{5(D-d)}$

Pendelrörelse

Pendelvinkeln översätts till rpm med följande formel:

$$rpm = \frac{2 \times C \times \text{pendelvinkel}}{360}$$

C = antal cykler per minut.

Beräkningsformeln för PV-värdet är enligt följande:

$$P = \frac{\text{Belastning (kg)}}{\text{utfallande yta (cm}^2\text{)}}$$

Utfallande yta = d x L

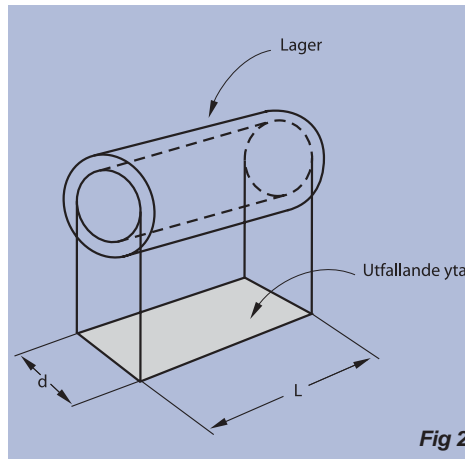

Belastning

	Driftförhållande		Max specifik belastning kg/cm ² (N/mm ²)
Statisk belastning	Långsam rörelse		1500 (147)
	Roterande, pendlande, linjär		600 (59)
Dynamisk belastning	Varierande last och/eller riktning	(upp till 100'000 ggr)	300 (29)
		(över 10'000'000 ggr)	150 (15)

Montering

Alla typer

NOMO glidlager bör inte borrar eller slipas i hålet eller på ytterdiametern. De levereras helt monteringsfärdiga. I de flesta förekommande fall är det helt tillräckligt med en krom- eller kolstålaxel med slipad yta, noggrannhet 0,4µm Ra. En för grov yta leder till ökat slitage.

Vid presspassning i huset elimineras slitisen i lagret. Denna skall dock inte läggas inom belastningsområdet. Inpressningen av NOMO radial- och flänslager sker lättast med hjälp av ett dorn (se fig nedan).

Radiallager

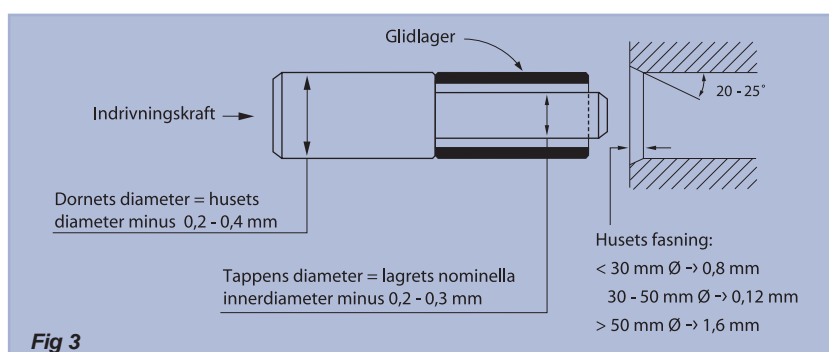

Flänslager

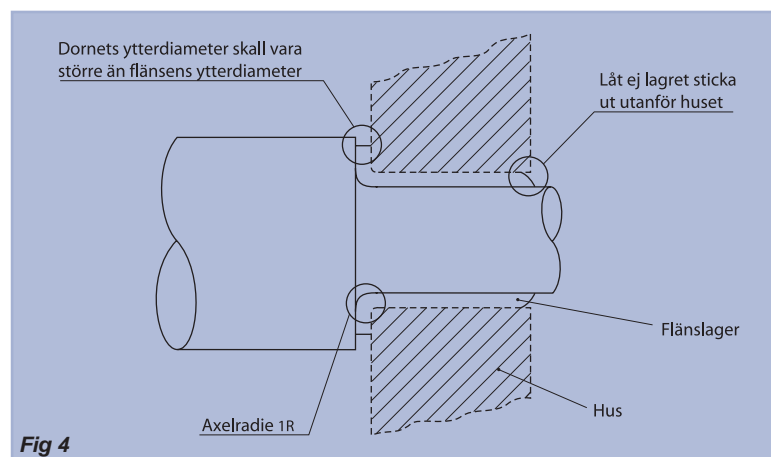

BUSSNINGAR I BRONS

Materialsammansättning

Typ	Cu%	Sn%	P%	Pb%	Zn%
FB/FBB	91,7	8	0,3	-	-

FB och FBB glidlager är tillverkade av homogen brons med god slitstyrka, korrosionsbeständighet och utmattningshållfasthet.

Bussningarna är avsedda för både radiella och axiella rörelser. De tillverkas med eller utan fläns och lämpar sig bäst till långsamma rörelser och höga belastningar.

Mekaniska egenskaper

Typ	Brottgräns N/mm ²	Sträckgräns N/mm ²	Förlängning %	Hårdhet HB	Friktions- koefficient
FB/FBB	450	250	55	90-120	0,08-0,25

Fysikaliska egenskaper

Typ	Densitet g/cm ³	Linjär expansion 20-300°C 10 ⁻⁶ /°C	Värmeled- ningsförmåga w/m×k	Elektrisk led- ningsförmåga m/ohm×mm ²
FB/FBB	8,9	18,2	60	6,5

Till hus med H7-tolerans bör axlar med tolerans e7 eller f7 användas, den invändiga diametern på glidlagret håller då H9-tolerans. Vid användning av h-axlar rekommenderas hustolerans F7. Axelhårdheten bör vara minst 150 HB, då erhålles bra lagring, låg friktion och lång användningstid.

Temperaturområden: FB/FBB 090 -80 ~ +200°C.
FB/FBB 092 -100 ~ +200°C.

Max glidhastighet: FB/FBB 090/092 2,5 m/s

Vårt sortiment av glidlager



NB1 Ptfе/Bly smörjfri.
Bärighet 140N/mm².
Temperaturområde -195°C ~ +280°C.
Max hastighet 5 m/s



NB1T Ptfе höga PV-värden
Bärighet 140N/mm².
Temperaturområde -195°C ~ +280°C.
Max hastighet 10 m/s



NB1P För fram- och återgående rörelse (Dd2). Bärighet 140N/mm².
Temperaturområde -195°C ~ +280°C.
Max hastighet 2,5 m/s



NB1W Ptfе blyfri
Bärighet 140N/mm².
Temperaturområde -195°C ~ +280°C.
Max hastighet 5 m/s



NB1B Högtemperatur
Bärighet 140N/mm².
Temperaturområde -195°C ~ +300°C.
Max hastighet 5 m/s



NB1D Hydraulikbussning (BP4)
Bärighet 140N/mm².
Temperaturområde -195°C ~ +280°C.
Max hastighet 3 m/s



NB1S Ptfе rostfri
Bärighet 140N/mm².
Temperaturområde -195°C ~ +280°C.
Max hastighet 2,5 m/s



NBPK PEEK, vattentätlig
Bärighet 100N/mm².
Temperaturområde -190°C ~ +250°C.
Max hastighet 2,5 m/s



NB2X Komposit
Bärighet 70N/mm².
Temperaturområde -40°C ~ +130°C.
Max hastighet 2,5 m/s



NB2Y Pom blyfri, smörjbar
Bärighet 70N/mm².
Temperaturområde -40°C ~ +130°C.
Max hastighet 2,5 m/s



NB2S Smörjfri, rostfri
Bärighet 70N/mm².
Temperaturområde -40°C ~ +130°C.
Max hastighet 5 m/s



FB090 Homogen brons
Bärighet 75N/mm².
Temperaturområde -130°C ~ +200°C.
Max hastighet 2,5 m/s

Vårt sortiment av glidlager



FB092 Homogen brons
Bärighet 60N/mm².
Temperaturområde -100°C ~ +200°C.
Max hastighet 2,5 m/s



JDB-1 Mässing med fasta smörjmedel
Bärighet 100N/mm².
Temperaturområde >300°C
Max hastighet 0,4-5 m/s



JDB-2 Bronslegering med fasta smörjmedel. Bärighet 60N/mm².
Temperaturområde >350°C.
Max hastighet 2 m/s



JDB-3 Bimetall med fasta smörjmedel
Bärighet 70N/mm².
Temperaturområde >300°C.
Max hastighet 2 m/s



JDB-4 Gjutjärn med fasta smörjmedel
Bärighet 60N/mm².
Temperaturområde >400°C.
Max hastighet 0,5 m/s



JDB-5 Segjärn med fasta smörjmedel
Bärighet 70N/mm².
Temperaturområde >350°C.
Max hastighet 2,5 m/s



JDB-1U Aluminium, koppar med smörjspår. Bärighet 100N/mm².
Temperaturområde >170°C.
Max hastighet 1,5 m/s



UF-850 Stål med sinterbrons
Bärighet 65N/mm².
Temperaturområde >260°C.
Låg hastighet



JF-800 Bimetall med sintrad glidyta
Bärighet 65N/mm².
Temperaturområde >260°C.
Medium hastighet



JF-720 Bimetall med sintrad glidyta
Bärighet 38N/mm².
Temperaturområde >170°C.
Hög hastighet



JF-700 Bimetall med koppar och bly
Bärighet 25N/mm².
Temperaturområde >170°C.
Hög hastighet



FB08G Stål/bly/brons med fasta smörjmedel. Bärighet 65N/mm².
Temperaturområde -100°C ~ +260°C
Max hastighet 4 m/s

Vårt sortiment av glidlager



FB090G Homogen brons med fast smörjmedel. Bärighet 65N/mm².
Temperaturområde -100°C ~ +260°C
Max hastighet 4 m/s



FU-1 Oljeimpregnerad sinterbrons
Bärighet 35N/mm².
Temperaturområde -80°C ~ +160°C



FU-2 Oljeimpregnerad sinterjärn
Bärighet 45N/mm².
Temperaturområde -80°C ~ +160°C



FU-1 Oljeimpregnerad sinterbronsjärn
Bärighet 45N/mm².
Temperaturområde -80°C ~ +160°C

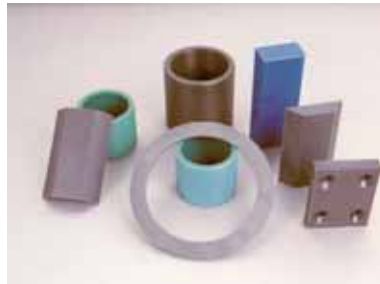

OMC Oljeimpregnerad nylon
Bärighet 14-20 MPa
Temperaturområde -40°C ~ +80°C



GFB Glasfiberförstärkt nylon
Bärighet 14-20 MPa
Temperaturområde -40°C ~ +80°C



TF-1 Blybronslegering
Bärighet 50 mm²
Temperaturområde > 300°C



TF-2 Blybronslegering med nickel
Bärighet 40 mm²
Temperaturområde > 400°C